

users guide

imax xtra

Your Ideal users guide

See reverse for **i**max xtra installation & servicing guide

Models F320, F400, F480, F560

When replacing any part on this appliance, use only spare parts that you can be assured conform to the safety and performance specification that we require. Do not use reconditioned or copy parts that have not been clearly authorised by Ideal Boilers.

i BOILERS **Ideal**
The High Efficiency Pioneers

imax xtra

Natural Gas only

PI No. 0063 BR 3123

Destination Countries: GB,IE

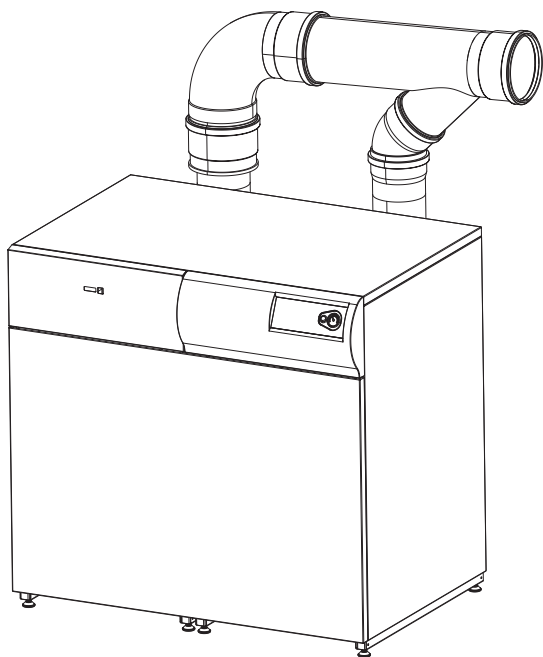

Introduction

The **imax xtra** boilers are fully automatically controlled, floor standing, fanned, super efficient condensing appliances.

Due to the very high efficiency, condensate is produced from the flue gases and this is drained to a suitable disposal point through the plastic waste pipe at the bottom of the boiler. A condensate 'plume' will also often be visible at the flue terminal.

Safety

Current Gas Safety (Installation & Use) Regulations or rules in force.

In your own interest, and that of safety, it is the law that this boiler must be installed and maintained by a CORGI registered installer or in IE a competent person, in accordance with the above regulations.

The appliance should be serviced at least once a year by a CORGI registered installer or in IE a competent person.

It is essential that the instructions in this booklet are strictly followed, for safe and economical operation of the boiler.

Electricity Supply

The appliance must be earthed.

Supply 230 V - 50 Hz. The fusing should be 7A for F320-F560.

This appliance is intended to be connected to the supply via two double-pole switches, having a 3mm contact separation in both poles, serving only the boiler and system controls. Alternatively, two 3-pin UNSWITCHED sockets may be used.

Important Notes

- This appliance must not be operated without the casing correctly fitted.
- Do not store objects around or on the boiler, and keep access clear at all times.
- Do not obstruct ventilation ducts, grilles or openings in the boiler room, room space or compartment that the appliance is installed in, or the passage of combustion and ventilation to the boiler.
- Do not turn off the boiler if it is to be left unattended in frosty weather.
- If it is known or suspected that a fault exists on the boiler then it **MUST NOT BE USED** until the fault has been corrected by a CORGI registered installer or in IE a competent person.
- Flammable materials must not be placed in close proximity to the appliance. Materials giving off flammable vapours must not be stored in the same room as the appliance.

In cases of repeated or continuous shutdown a CORGI registered installer or in IE a competent person should be called to investigate and rectify the condition causing this and carry out an operational test after each intervention on the device. Only the manufacturers original parts should be used for replacement.

Minimum Clearances

Rear:

1000mm or adequate space from the rear of the jacket to make the flue connections and access to the flue sample point, drain connection, flue and any safety or control devices.

Left Side:

450mm.

Right Side:

450mm.

Front:

600mm; except, access doors may be closer, but not less than 200mm and 600mm must still be available for service across the width of the boiler.

Top:

500mm.

To light the boiler (Refer to Frame 1)

1. CHECK THAT THE ELECTRICITY SUPPLY TO THE BOILER IS OFF.
2. Set the burner on/off switch (A) to off.
3. Switch on the electricity supply to the boiler and check that all external controls, e.g. programmer, room thermostat etc. are on. Allow the boiler to carry out a self check.
4. Set the burner on/off switch (A) to ON.

The boiler will commence the ignition sequence, supplying heat to the system when required.

All CORGI Registered Installers carry a CORGI ID card, and have a registration number. Both should be recorded in your Log Book. You can check your installer by calling CORGI direct on 01256 372 300.

CAUTION. To avoid the possibility of injury during the installation, servicing or cleaning of this appliance care should be taken when handling edges of sheet steel components.

1 BOILER CONTROLS / DISPLAY (MASTER PANEL SHOWN)

LEGEND

A. Burner switch	E. Mode button
B. Pressure gauge	F. Step button
C. Display	G. Store button
D. Reset button	H. + button (to increase values)
	I. - button (to decrease values)

SLAVE MODULE CONTROL PANEL

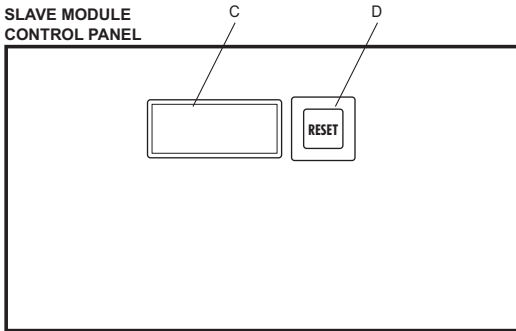

MASTER MODULE CONTROL PANEL

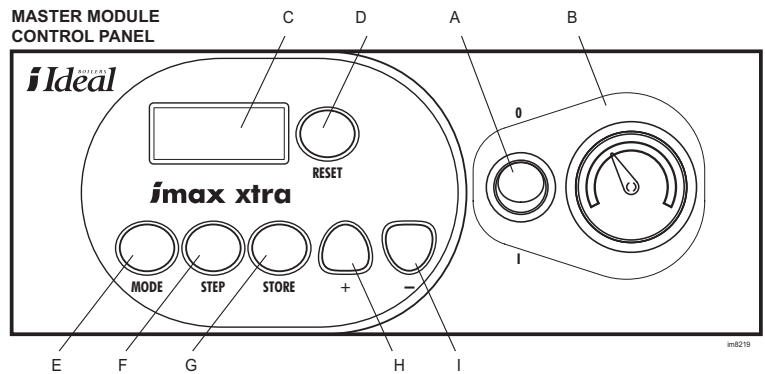

Operation

Sequence	Boiler Status
A	DHW valve energised
0	Standby, no heat request
1	Pre-purge, post purge
2	Ignition
3	Burner on in CH mode
4	Burner on in DHW mode
5	Waiting for air pressure switch to open or close
6	Burner off because a set value has been reached
7	Pump overrun in CH mode
8	Pump overrun in DHW mode

In normal operation the display (C) shows the boiler status (see table above) and the water system flow temperature.

Blocking Mode

The boiler will enter blocking mode under certain fault conditions. Whilst in blocking mode the burner is switched off. Once the fault conditions are clear the boiler will automatically reset itself. In blocking mode the display will alternate between showing a '9' in digit one, along with the flow temperature in digits 2, 3 and 4, e.g.

9 9 6

Followed by the blocking code 'bxx', e.g.

b 1 8

Error Mode

In error mode the display will flash on and off with the error code shown, e.g.

E 3 6

The boiler will enter error mode under certain fault conditions. The unit will be inoperative until the fault is rectified. The reset button is used to reset the boiler control module after an error has occurred.

Self Check and Anti-Seize Modes

After switching on the mains power or after a reset, the boiler performs a selfcheck, i.e. the DHW valve (if connected) is energised first for 15 seconds then the CH pump is switched on for a further 10 seconds. This cycle repeats itself every 24hrs, as long as no heat request is given in 24hrs.

Burner on/off Switch

With the burner switch set to 'off' the boiler will not respond to a CH demand. However, it will respond to a DHW demand and the pump anti-seize and frost protection modes are still operational any one of which could cause the boiler to fire. Note. The burner switch is NOT a mains isolation switch.

CH/DHW Systems

In standby mode pressing and holding the '+' button for 3 seconds turns the CH system on/off.

In standby mode pressing and holding the '-' button for 3 seconds turns the DHW system on/off.

To shut Down the Boiler

1. For short periods

Set the external controls to OFF. Wait 10 minutes and then isolate the mains supply to the boiler.

2. For longer periods

Set the external controls to OFF. Wait 10 minutes and then isolate the mains supply to the boiler. For longer periods the entire system should be drained, including the domestic hot water supply.

To Relight the Boiler

Refill the system if it has been drained, taking care to ensure no air is in the boiler or system.

Repeat the procedure detailed in 'To light the boiler'.

Frost Protection

The **imax xtra** boiler has built into its control system the facility to protect the boiler only against freezing.

Note.

This may not protect remote parts of the system, in which case a separate frost protection should be fitted.

Boiler Overheat

Boiler overheating is detected by electrical sensors connected to the boiler control module. If the boiler overheats it will shut down and the display will show E18. Press the 'reset' button (D) and the boiler will relight. If the fault recurs turn off the boiler and consult a CORGI registered installer or in IE a competent person.

Condensate Drain

The condensate drain must not be modified or blocked.

Blockage of the condensate drain, caused by debris or freezing, can cause automatic shutdown of the boiler or leakage from the condensate trap mounted on the bottom of the boiler.

If freezing is suspected and the pipe run is accessible an attempt may be made to free the obstruction by pouring hot water over the exposed pipe and clearing any blockage from the end of the pipe. If this fails to remedy the problem the assistance of a CORGI registered installer or in IE a competent person should be sought.

Escape of Gas

Should a gas leak or fault be suspected contact your local gas supplier without delay.

Do NOT search for gas leaks with a naked flame.

Cleaning

For normal cleaning simply dust with a dry cloth.

To remove stubborn marks and stains use a damp cloth and mild detergent.

DO NOT use abrasive cleaning materials.